

Using the JoJo Tank Mozzie Screen

Mosquito-proof your water storage tank by fitting our Tank Mozzie Screen to your overflow or inlet.

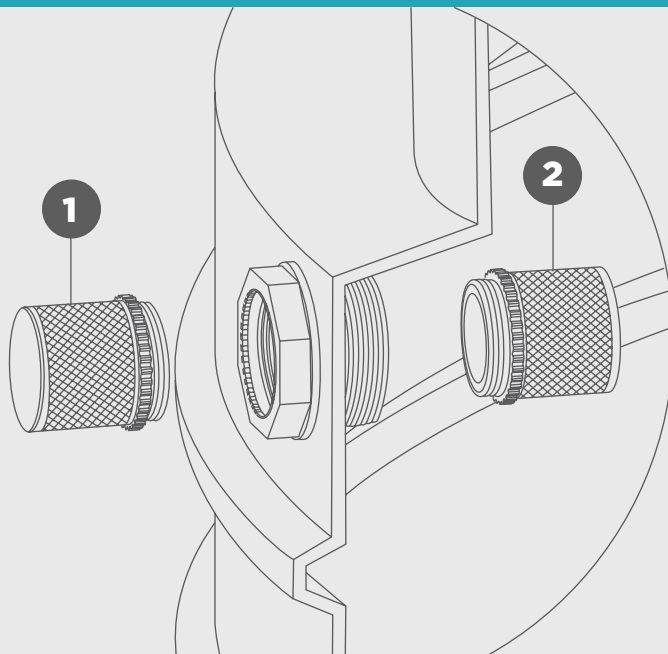

This 40mm Tank Mozzie Screen allows water to pass through the overflow while blocking entry for mosquitoes and other insects. It improves the quality of water stored and promotes ventilation and circulation.

COMPONENTS REQUIRED



40mm
Tank Mozzie Screen

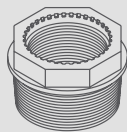

50/40mm
Full Thread Reducer

Note:

If you want to fit this accessory to the inside of your inlet (as per option 2 in the above illustration), and you bought a JoJo water tank prior to the year 2020, you will need to purchase our Full Thread 50/40mm Reducer (inlet /overflow fitting).

ASSEMBLY

Option 1

Connect the Mozzie Screen to the outside of the tank overflow or inlet if not connected to a pipe supply.

Option 2

Connect the Mozzie Screen to the inside of the tank inlet (this allows you to utilise the external connection point for another purpose).

Important:

It is advised to use thread tape for all connections.